

NAŠ MALI ŠKVER



Program Mali škver namijenjen je učenicima osnovnih i srednjih škola iz cijele Hrvatske, te njihovim profesorima i učiteljima. Program objedinjava različite tehnike brodomaketarstva i obradu materijala te ima za cilj čuvati pomorsku baštinu Kvarnera i Republike Hrvatske.

Dvije su ciljane skupine: učenici i profesori. U provedbi radionica koriste unaprijed laserski izrezani drveni kitovi tradicionalnih drvenih barki jadranskog primorja. Učenici savladavaju korištenje materijala i alata i praćenje uputa za izradu maketa, vježbaju preciznosti i stprljivost, te istovremeno uče kako produktivno iskoristiti vrijeme tijekom ili izvan nastave. Profesori se obučavaju za mentore kako bi mogli nastaviti provoditi radionice s učenicima, te pritom upoznaju i usavršavaju nove, "hands-on" metode poučavanja i pripadajuće materijale, te razvijaju ideje za nove projekte na temelju stečenih vještina.



CILJEVI PROJEKTA

Glavni cilj ovog programa je potaknuti razvoj i promociju brodomaketarstva kao izvannastavne aktivnosti u Republici Hrvatskoj. Brodomaketarstvo se ističe kao kvalitetan način provođenja slobodnog vremena, istovremeno njegujući tradiciju i baštinu hrvatske brodogradnje te razvijajući fine motoričke vještine kod korisnika.

Za provedbu programa pripremljeni su kitovi za izradu maketa tradicionalnih hrvatskih brodica, pripremljen je materijal i popis potrebne opreme, kao i video priručnici za mentore i sudionike. Svi materijali su prilagođeni za online edukaciju kako bi se program mogao provoditi u svim uvjetima. Mentorstvo i edukacija su također dostupni online, prema potrebi. Radionice su namijenjene trenerima i učenicima.

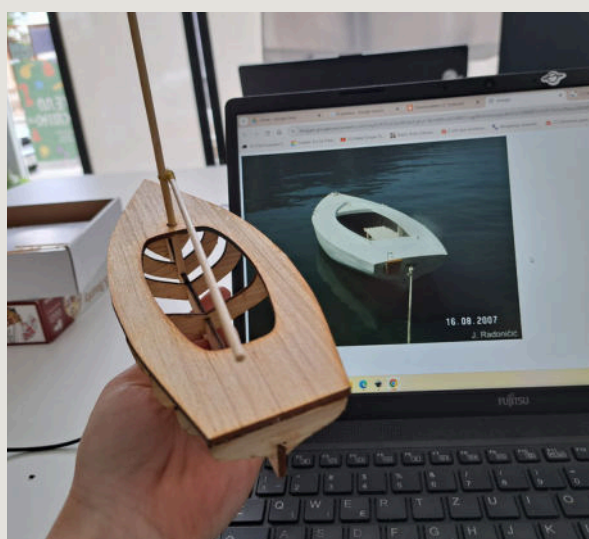

ZNANJA I VJEŠTINE

Nakon provedenog osposobljavanja, treneri pomažu izrađivati makete brodova unutar svojih škola ili udruga. Djeca i mladi, putem izvannastavnih i izvanškolskih aktivnosti, imaju priliku stjecati znanja i vještine obrade materijala, izrade i čitanja nacрта, te su upoznawali hrvatske brodice, način njihove uporabe i plovidbe.

Kroz ovaj program, na pristupačan način, mladima se pružaju informacije o pomorstvu i brodovima u Hrvatskoj i diljem svijeta, potičući ih na promišljanje o tradiciji i pomorskoj baštini, kao i na zanimanje za stara zanimanja. Kvalitetnim korištenjem slobodnog vremena, potiče se druženje među djecom te razvoj interesa za tehničke aktivnosti.



NAŠE MAKETE

PASARA



Pasara je drvena barka, a kasnije se počela izrađivati i od plastike. Takve plastične pasare mogu se vidjeti u svakoj lučici na jadranskoj obali.

Trup je oble forme sa zrcalnom (ravnom) krmom. Upotrebljava se za priobalne potrebe poput ribarstva, prijevoza tereta i dnevne izlete.

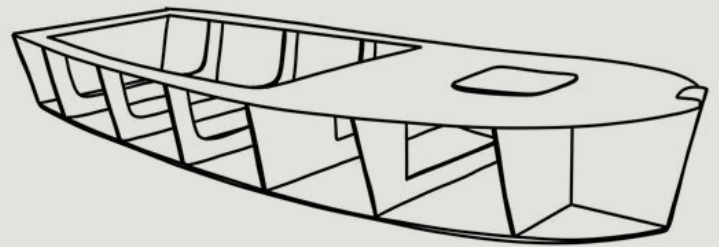

Nekada je bila opremljena jarbolom i jedrima, a danas motorizirana.

Naziv joj dolazi od talijanskog jezika - passara = list (riba), zbog toga što su pasare prvenstveno korištene za lovljenje listova.



NAŠE MAKETE

PRIMORSKA

BARKA



Primorska barka nastala je od pasare, a dodane su joj kabina i natkabina za višednevni boravak na moru, bilo za ribolov bilo za odmor.

Osim kabine u kojoj se može prespavati, natkabina služi kao zaklon od kiše i vjetrova za vrijeme kormilarenja.

Ugrađuju se motori, ležajevi, kuhinja, toalet, rasvjeta itd.

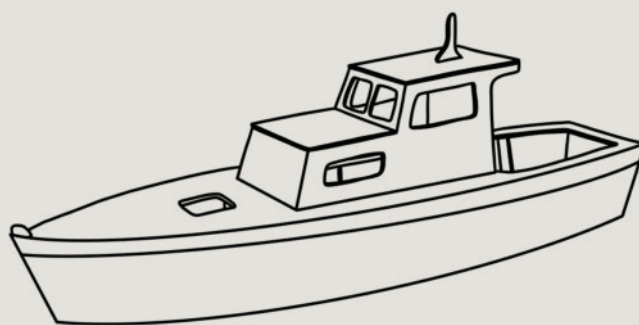

NAŠE MAKETE

LIBURNA



Liburna je antički ratni brod na jedra i vesla. Naziv je dobio po ilirskom plemenu Liburnima, od kojega su tu vrstu broda preuzeli Rimljani, vjerojatno u I. st. pr. Kr.

Vitak trup broda bio je izuzetno okretan i dobrih svojstava na manevriranje, a unatrag savijena pramčana statva imala je kljun ispod vodne linije na pramcu, koji je mogao probiti trup drugog broda. Liburna je imala jedan red vesala te jedan jarbol s križnim jedrom.

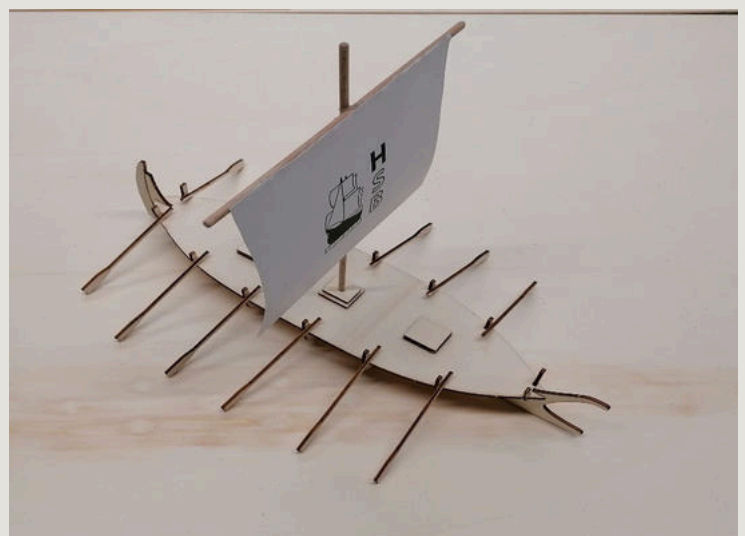
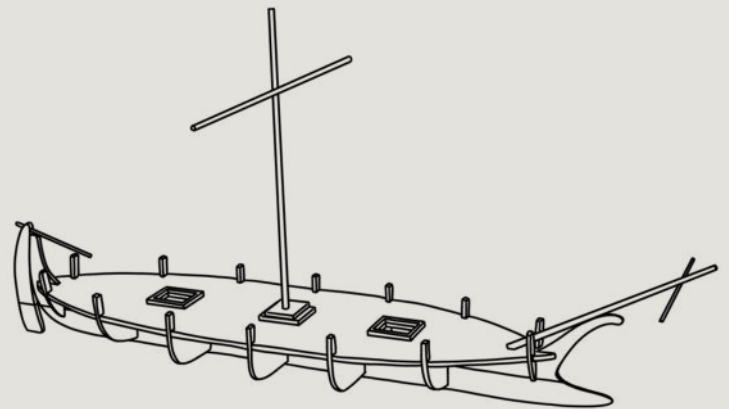

NAŠE MAKETE BRACERA



Teretni drveni jedrenjak opremljen jednim jarbolom i jedrima, karakterističan za otok Brač. Trup dužine 15- ak metara, zdepast, prilično velike nosivosti za svoju veličinu.

Bracera je najčešće služila za prijevoz različitih vrsta terete i roba, poput maslinovog ulja, vina, kamena i drvene grade.

Među naizgled sličnim jedrenjacima, braceru je najlakše prepoznati po dva šareno obojana "oka" na pramcu.

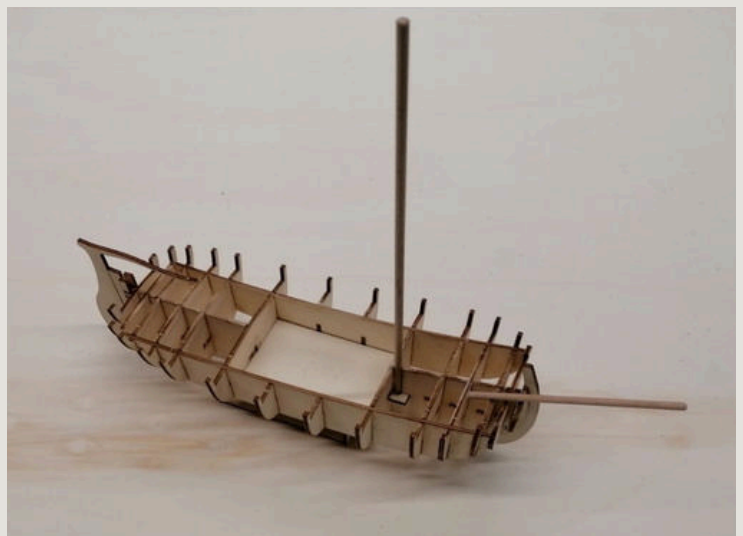
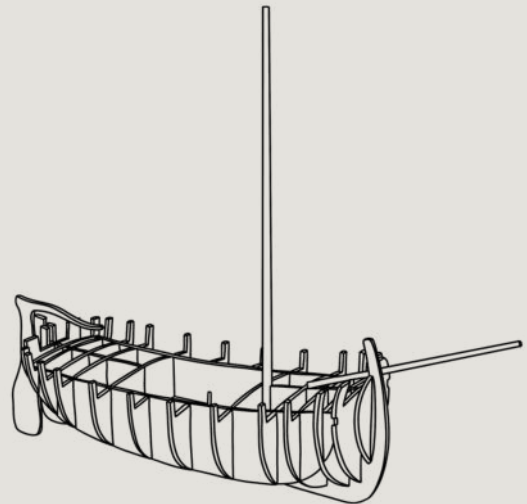

NAŠE MAKETE

KAJAK

Lagano, usko plovilo kojim se upravlja pomoću vesla.

Paluba mu je zatvorena, osim prostora u kojem veslač sjedi ispruženih nogu.

U davna vremena koristio se za lov, no danas se koristi za sport i razonodu.

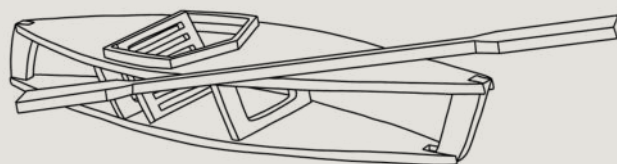

NAŠE MAKETE

NERETVANSKA TRUPICA



Neretvanska trupica služila je poljodjelicima da kroz kanale i rukavce stignu do svojih polja u dolini Neretve. Tako je lagana da je dvoje ljudi može lako nositi. Ima ravno dno i može prenijeti 200-250 kg tereta. Duga je oko 4m, a široka najviše 90 cm, što je čini prilagođenom za uske prolaze kroz nasade i trstiku.

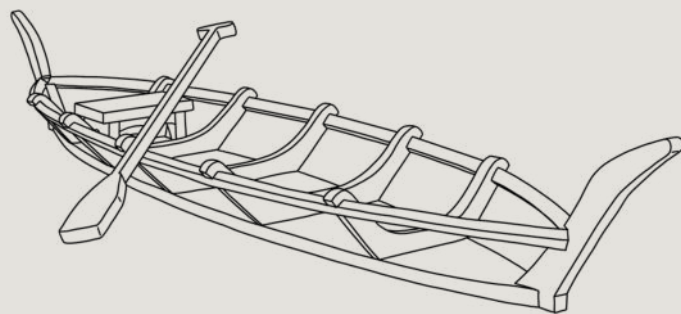

NAŠE MAKETE

LUČKI REMORKER

Lučki remorker je vrsta broda koja se koristi za vuču, tegalj, guranje drugih plovniha objekata. Koristi se u lukama, moru, širokim rijekama i kanalima. Iznimna snaga porivnog stroja naspram veličine plovila omogućava mu vuču brodova mnogo većih od sebe. Obično se remorkeri mogu vidjeti kod porinuća brodova, kao i dok veći brodovi uplovljavaju u luke u kojima im je ograničena upravljivost.

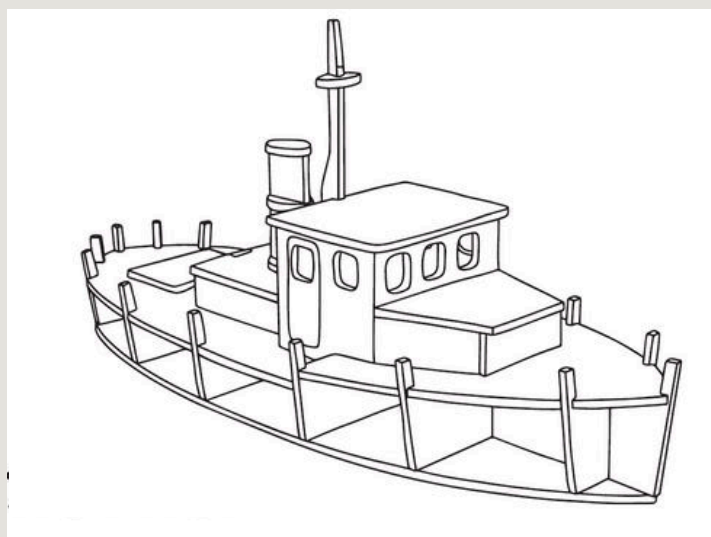

NAŠE MAKETE

LUČKI

REMORKER



Remorker ili tegljač je brod koji se koristi za tegljenje, vuču ili okretanje drugih plovila. Obično su to plovila koja su mnogo veća od remorkera, ali teže upravljiva. Jeste li znali da remorker često ima pramac i bokove pokrivene gumom, kako bi mogao gurati ili držati na mjestu druge brodove. To se zove "boksanje"! Pritom se remorker pramcem oslanja na posebna mjesta na bokovima broda, gdje je struktura ojačana i ne mogu nastati oštećenja. Ta mjesta lako je uočiti na brodu - oznaka je "TUG".

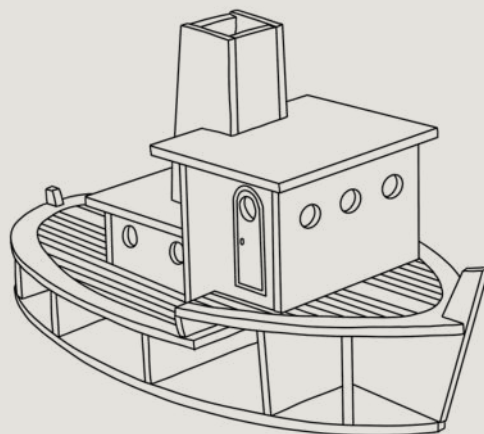

NAŠE MAKETE

RAPSKA LAĐA



Rapska lađa stoljećima je bila glavno sredstvo plovidbe na otoku Rabu. Najstariji zapis o gradnji potječe iz 1268. Gradila se rezbarenjem debela smreke s Velebita. Plovilo građeno urezivanjem naziva se monoksil. Deblo bi se prvo sušilo nekoliko godina, zatim obrađivalo do željenog oblika, a u deblo su umetnuta rebra, nakčešće od hrastovine. Rapska lađa koristila se za ribolov, prijevoz manjeg tereta i ljudi duž obale.

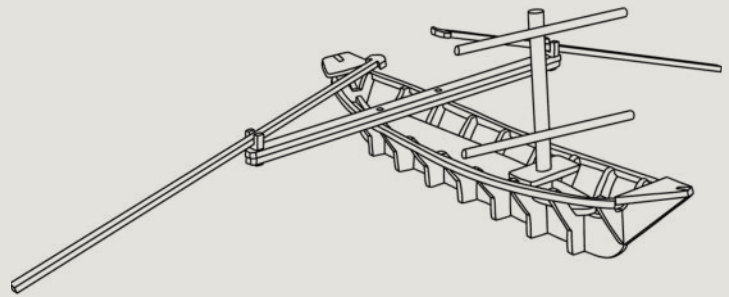

NAŠE MAKETE

BATEL



Batel podsjeća na pasaru, međutim ima prednji jarbol koji se može po potrebi skinuti. Koristio se najčešće za prijevoz tereta i putnika kao svojevrsno taksi plovilo. Još do prije 30-ak godina prometovala su takva taksi - plovila između manjih mjesta na obali, npr. na relaciji Kraljevica - Oštro.

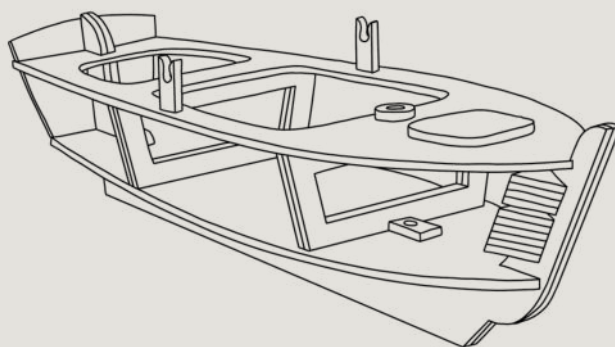

NAŠE MAKETE

JEDRILICA L5

Jedrilica L5 je bila nacionalna jedriličarska klasa u 20. stoljeću, dužine oko 5 metara. Prva jedrilica L5 imala je fiksnu kobilicu, a naredne 1928. godine napravljen je prototip jedrilice s pomičnom kobilicom. Narednih godina radilo se na optimizaciji i poboljšavanju broda.

Gradile su se jedrilice sa sve boljim trupovima, a sve su imale ženska imena s početnim slovom L. Neka od tih imena bile su Lada, Leda, Luna, Lavsa i Lenka. U žargonu, jedrilice klase L5 svi su zvali elerice. Na slici se može vidjeti Lavsa.



NAŠE MAKETE

ISTARSKI TOPO

topo je poluopalubljena lagunska brodica na vesla i jedra prepoznatljiva po uskoj građi, kojom su ribari isporučivali ribu na odredište. Topo se tradicionalno rabio na sjevernom Jadranu, a bio je duljine 6–10 m. Duljina je zbog plitke konstrukcije bila ograničena, jer bi se preduga natovarena brodica na valovima mogla prelomiti.

Naziv "topo" dolazi od talijanske riječi za "miš", a ova brodica je dobila taj općeprihvaćeni nadimak zbog uzignutog šiljastog pramca, koji podsjeća nja mišju njuškicu.

